

5818 ROUTE 9H & 23 HUDSON, NY 12534

SEPTIC TANKS  
DRY WELLS  
D-BOXES  
CATCH BASINS



STEPS  
CURBING  
WHEEL STOPS  
CUSTOM WORK

PRECAST CONCRETE PRODUCTS

518-851-6281  
518-851-9134  
FAX 518-851-7835

### MODEL 30 C/B 30" X 30" ID CATCH BASIN WITH 2- PREFORMED HOLES

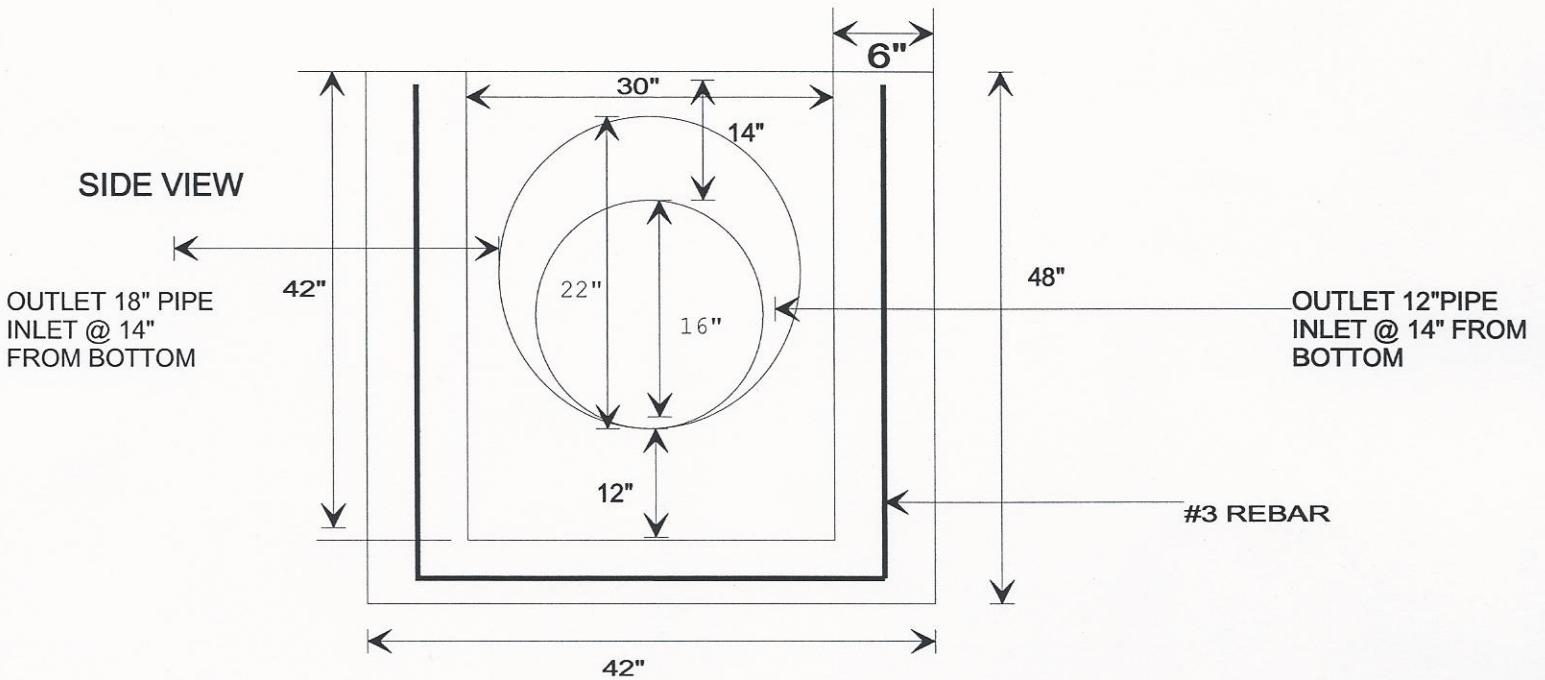
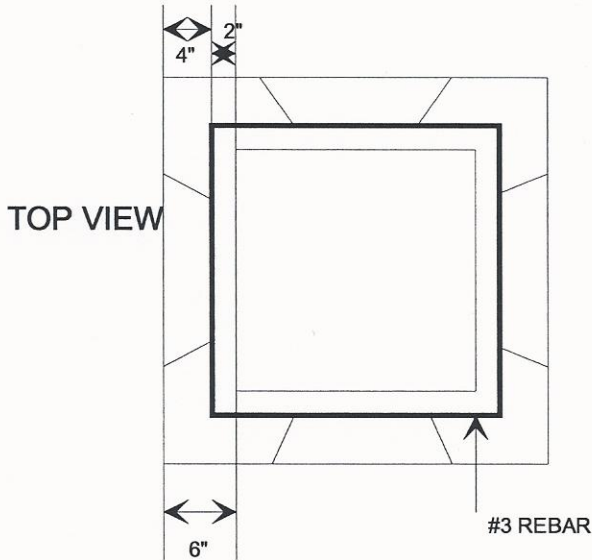

Specifications: Concrete minimum strength 5000 psi at 28 days  
Air entrainment- minimum 5%  
Reinforcement- Gal. WWM and/or Euclid Tuf Strand SF Fiber(6 lbs./yd.)  
# 3 Rebar  
2-Preformed holes for 12" or 16" pipe, opposite sides, 12" sump

WEIGHT: 3650 LBS.

3/31/09

**ROUND AND SQUARE GRATINGS ARE AVAILABLE.**