

5818 ROUTE 9H & 23 HUDSON, NY 12534

SEPTIC TANKS
DRY WELLS
D-BOXES
CATCH BASINS

**KEELER
VAULT
CO.**

STEPS
CURBING
WHEEL STOPS
CUSTOM WORK

PRECAST CONCRETE PRODUCTS

518-851-6281
518-851-9134
FAX 518-851-7835
www.keelervault.com

MODEL 2000-P
STANDARD 2000 GALLON PUMP TANK
ONE COMPARTMENT
3 INLETS 1 OUTLET

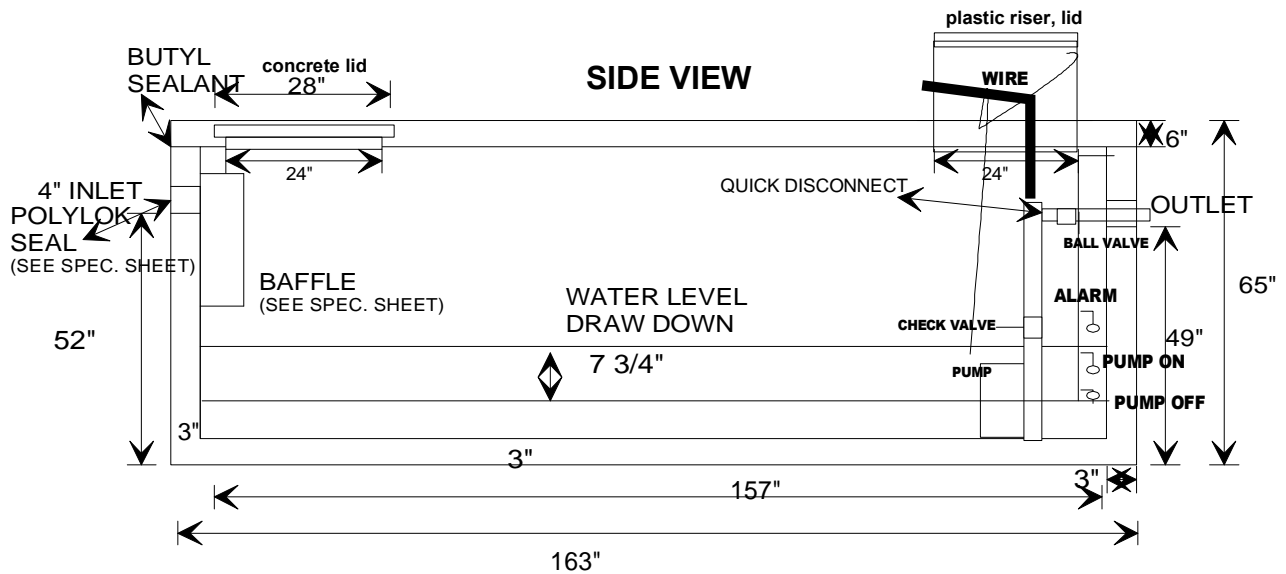
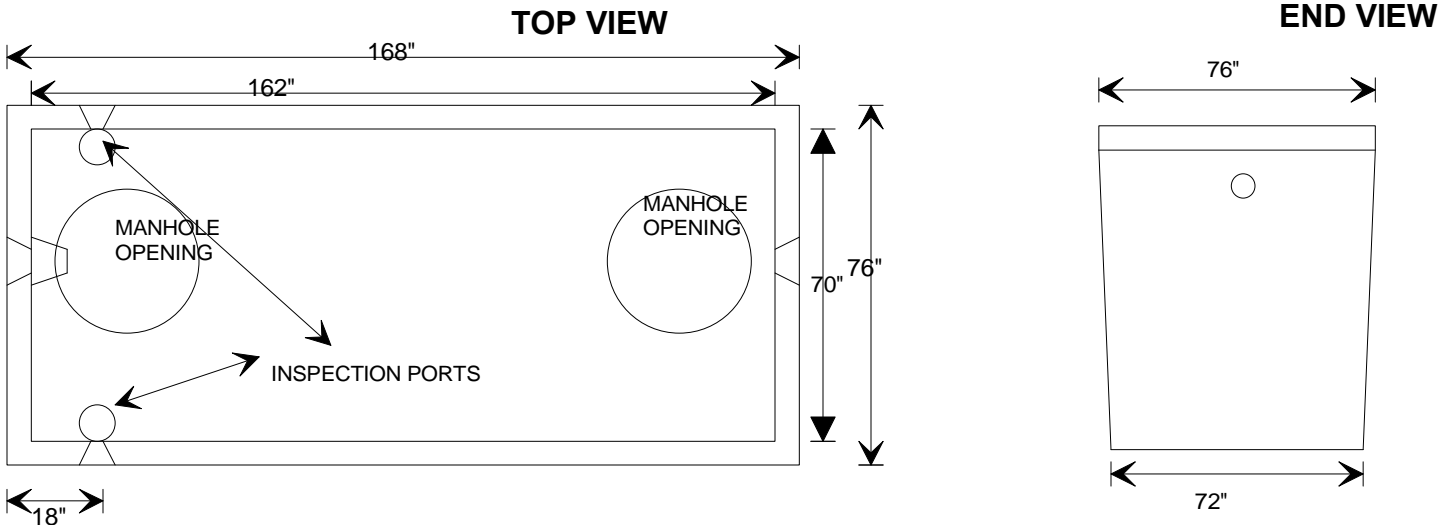

Single Pump, Check Valve, Quick disconnect, Ball Valve, Outdoor Panel with alarm, 3 float switches with weights, Float Bracket, Weep hole, SS Wire Rope
DRAW DOWN IS 45.65 GALLONS/INCH
Draw down should not be less than 4" due to float design.

WEIGHT: 17,405 LBS.

MAXIMUM RECOMMENDED DEPTH OF COVER OVER TANK- 3 FEET

Specifications: Concrete minimum strength-5000 psi at 28 days
Air entrainment - minimum 5%
Reinforcement- Base: Euclid Tuf Strand SF Fiber (6lbs./yd)
#3 Grade 60 deformed rebar
Lid: #4 Grade 60 deformed rebar
Pipe connections - Polylok seals (patented)
Baffles - Plastic inlet (patented)
Inspection ports above each pipe connect.