

5818 ROUTE 9H & 23 HUDSON, NY 12534

SEPTIC TANKS
DRY WELLS
D-BOXES
CATCH BASINS

KEELER
VAULT
CO.

STEPS
CURBING
WHEEL STOPS
CUSTOM WORK

PRECAST CONCRETE PRODUCTS

518-851-6281
518-851-9134
FAX 518-851-7835

DOUBLE REINFORCED PADS

SIZE: 18" X 18" X 2"

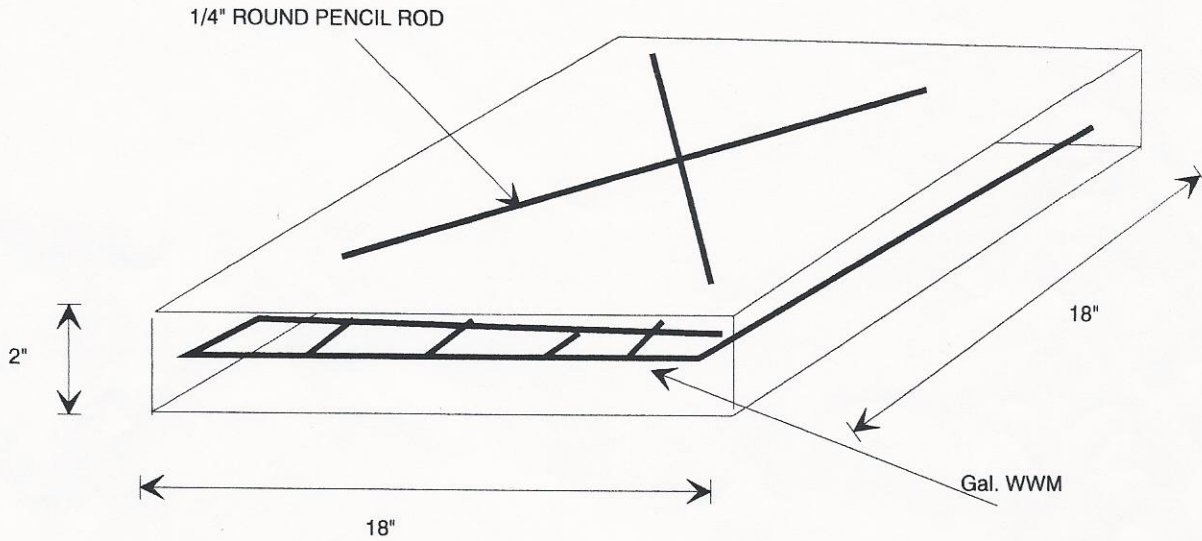

Specifications: Concrete minimum strength-5000 psi at 28 days
Air entrainment- minimum 5%
Reinforcement- 1/4" pencil rod and Gal. WWM in all.

WEIGHT: 54 LBS.