

5818 ROUTE 9H & 23 HUDSON, NY 12534

SEPTIC TANKS
DRY WELLS
D-BOXES
CATCH BASINS



STEPS
CURBING
WHEEL STOPS
CUSTOM WORK

PRECAST CONCRETE PRODUCTS

518-851-6281
518-851-9134
FAX 518-851-7835

MODEL 18 C/B 18" X 18" ID CATCH BASIN

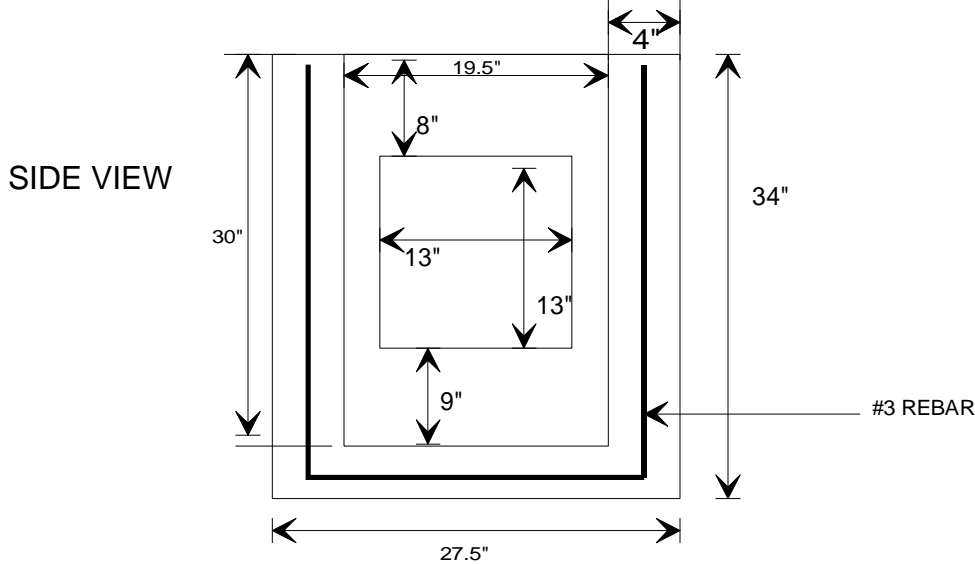
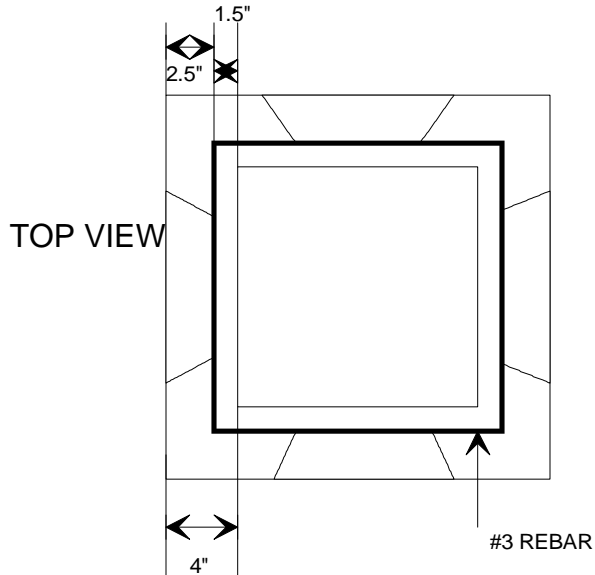

Specifications: Concrete minimum strength 5000 psi at 28 days

Air entrainment- minimum 5%

Reinforcement- Gal. WWM and/or Euclid Tuf Strand SF Fiber(6 lbs./yd.)

3 Rebar

Knockout area- 13" x 13" on all four sides

WEIGHT: 1120 LBS.

SQUARE FRAME AND GRATES ARE AVAILABLE.