

5818 ROUTE 9H & 23 HUDSON, NY 12534

SEPTIC TANKS  
DRY WELLS  
D-BOXES  
CATCH BASINS

**KEELER  
VAULT  
CO.**

STEPS  
CURBING  
WHEEL STOPS  
CUSTOM WORK

PRECAST CONCRETE PRODUCTS

**518-851-6281**  
**518-851-9134**  
**FAX 518-851-7835**  
**www.keelervault.com**

**MODEL 1500-S2C**  
**STANDARD 1500 GALLON SEPTIC TANK**  
**TWO COMPARTMENT**  
**3 INLETS 1 OUTLET**

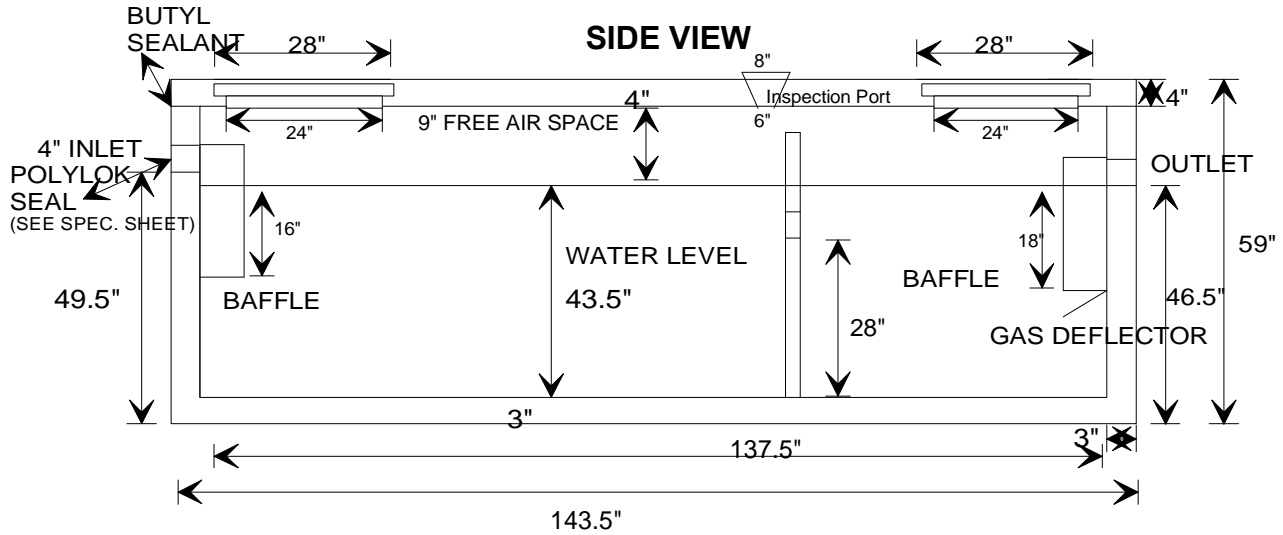
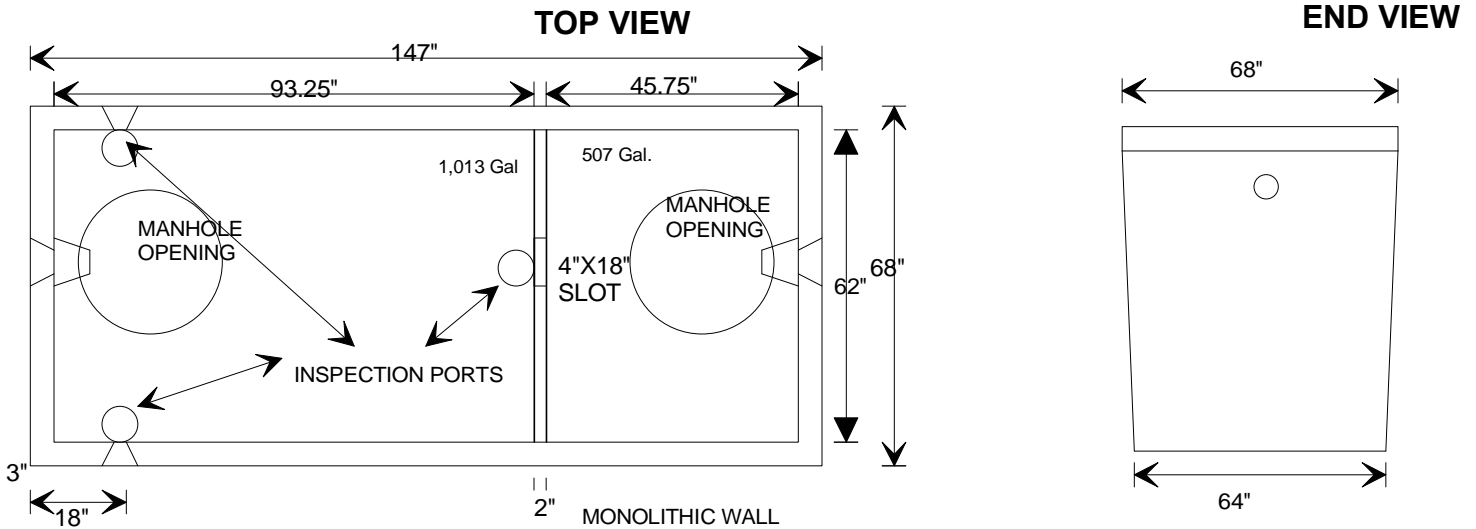

Specifications: Concrete minimum strength-5000 psi at 28 days  
Air entrainment - minimum 5%  
Reinforcement- Base: Euclid Tuf Strad SF (6lbs./yd.)  
#3 Grade 60 deformed rebar  
Lid: #4 Grade 60 deformed rebar  
Pipe connections - Polylok seals (patented)  
Baffles - Plastic Polylok inlet and outlet  
w/gas deflector (patented)  
Inspection ports above each pipe connect.

**WEIGHT: 13,000 LBS.**

MAXIMUM RECOMMENDED DEPTH OF  
COVER OVER TANK- 3 FEET

SEE REVERSE SIDE FOR REINFORCEMENT POSITIONING