

5818 ROUTE 9H & 23 HUDSON, NY 12534

SEPTIC TANKS
DRY WELLS
D-BOXES
CATCH BASINS

**KEELER
VAULT
CO.**

STEPS
CURBING
WHEEL STOPS
CUSTOM WORK

PRECAST CONCRETE PRODUCTS

518-851-6281
518-851-9134
FAX 518-851-7835
www.keelervault.com

MODEL 1000-S2C
STANDARD 1000 GALLON SEPTIC TANK
TWO COMPARTMENT
1-WASTE COMP. 1-PUMP COMP.
3 INLETS 1 OUTLET

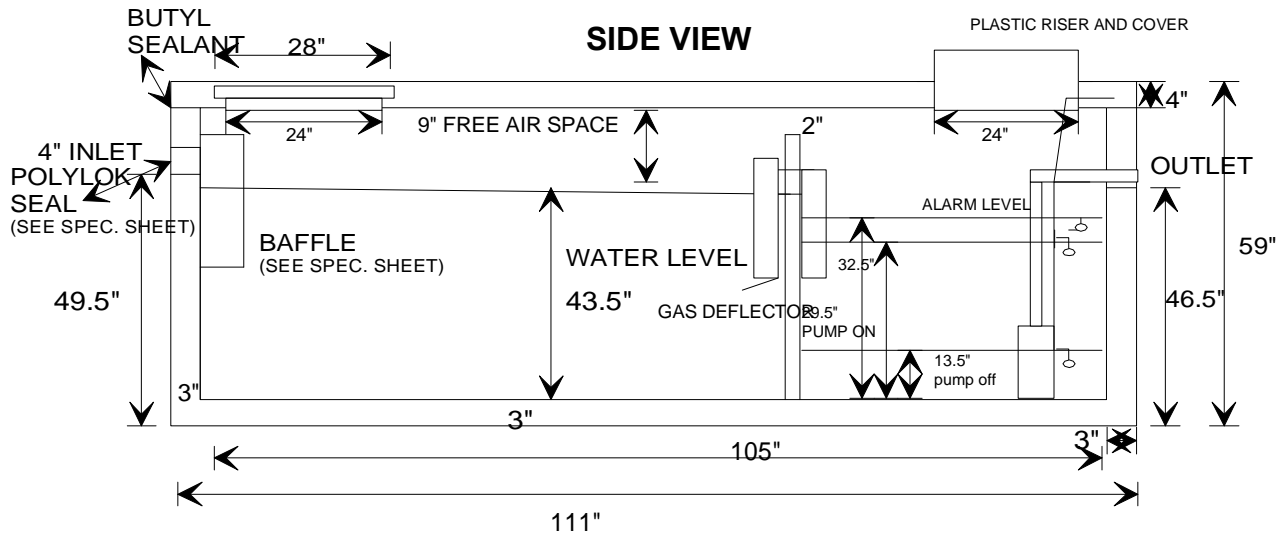
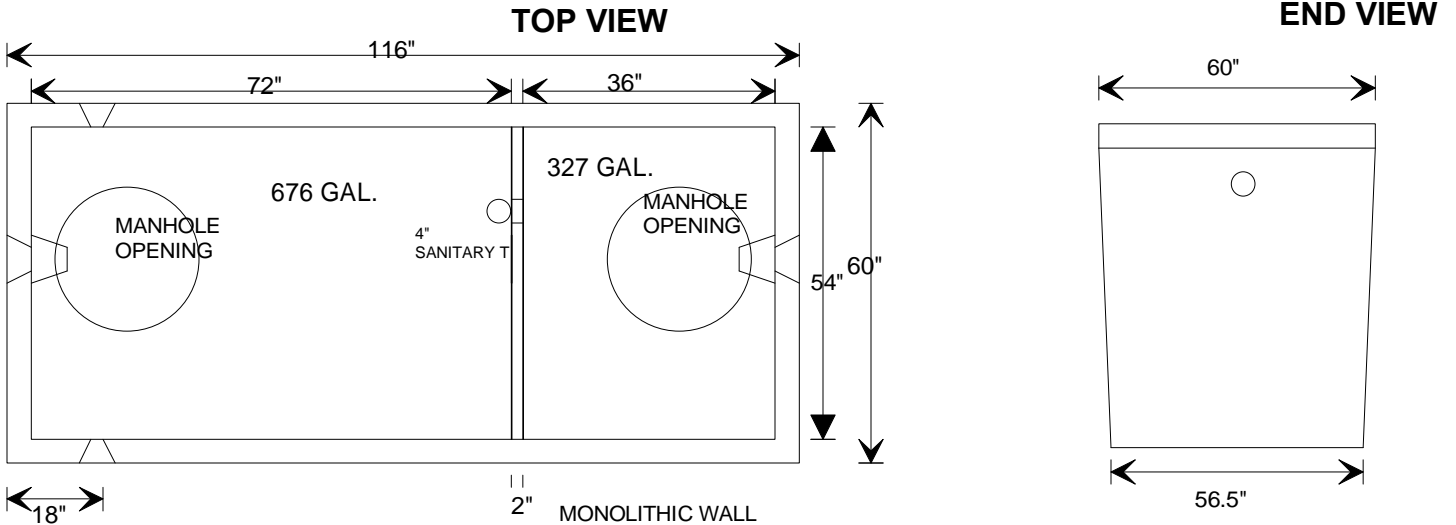

Specifications: Concrete minimum strength-5000 psi at 28 days
Air entrainment - minimum 5%
Reinforcement- Base: Euclid Tuf Strand SF Fiber (6lbs./yd)
#3 Grade 60 deformed rebar
Lid: #4 Grade 60 deformed rebar
Pipe connections - Polylok seals (patented)
Baffles - Plastic inlet, **4" T baffle on either side of wall**
Pump: Gould WEO311L, outdoor control panel, check valve, quick disconnect, ball valve, weep hole, drawdown (7.8gal./inch)

WEIGHT: 9,605 LBS.

MAXIMUM RECOMMENDED DEPTH OF COVER OVER TANK- 3 FEET