

5818 ROUTE 9H & 23 HUDSON, NY 12534

SEPTIC TANKS  
DRY WELLS  
D-BOXES  
CATCH BASINS

**KEELER  
VAULT  
CO.**

STEPS  
CURBING  
WHEEL STOPS  
CUSTOM WORK

PRECAST CONCRETE PRODUCTS

518-851-6281  
518-851-9134  
FAX 518-851-7835  
www.keelervault.com-

MODEL 1000-HS20C1  
H20-1000 GALLON PUMP TANK  
3 INLETS 1 OUTLET

TOP VIEW

END VIEW

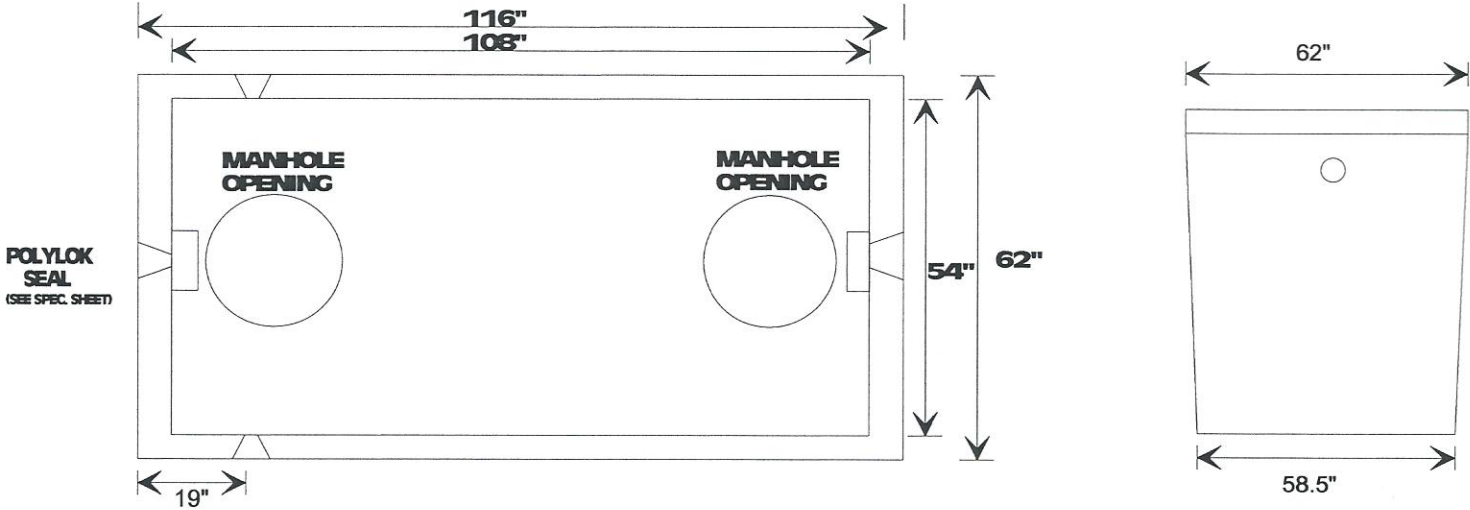

2-[WEO318L Gould Pump, check valve, ball valve, lift out cable, slide rail w/lift out adaptor], float bracket, 3 switches w/weights, Duplex indoor control panel w/alarm, venting done on site by others  
**DRAW DOWN IS 23.1 GALLONS/INCH**

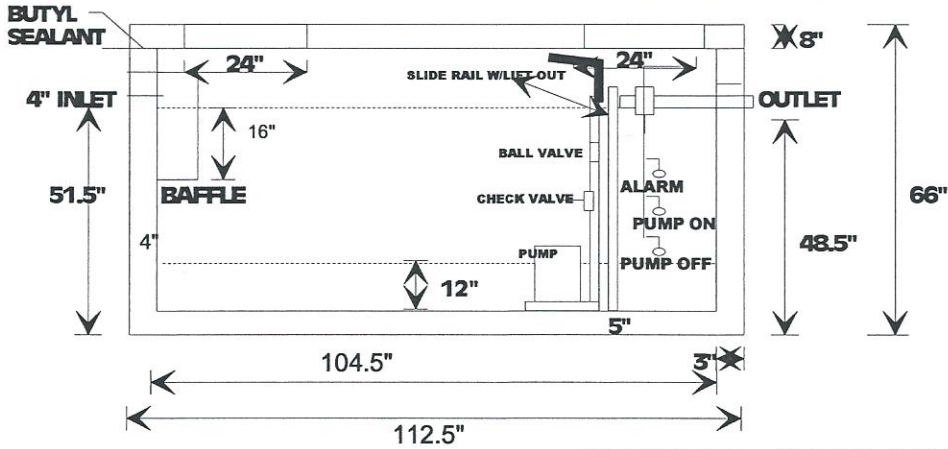

Water tight 24"  
Cast Iron Frame & Lids  
Available and Recommended

SIDE VIEW

**WEIGHT: 15,100 LBS.**

MAXIMUM RECOMMENDED DEPTH OF COVER OVER TANK-3 FEET

Specifications: Concrete minimum strength-5000 psi at 28 days  
Air entrainment - minimum 5%  
Reinforcement- Base: #3 Grade 60 deformed rebar  
Lid: #4 Grade 60 deformed rebar  
Pipe connections - Polylok seals (patented)  
Baffles - Plastic Polylok inlet  
**CAST IRON FRAME & LIDS ARE RECOMMENDED**  
**Stamped Engineered Plans Available(tank only)**

SEE REVERSE SIDE FOR REINFORCEMENT POSITIONING